

MINCO

AC1009 (20 AMP) DC SOLID STATE RELAY

INSTRUCTIONS

Installation Instructions

When using a Solid State Relay (SSR), it is essential that you remove heat from it. Whether mounting a SSR to a heatsink or to the side of a control cabinet, a thermal transfer medium should be used between the relay's base plate and the surface. Install the supplied thermal pad (white-coated aluminum foil the size and shape of the base plate of the SSR) as shown. If the thermal pad is damaged, substitute normal thermal grease.

Make sure that the power is turned off. Using the SSR's hardware, screw it tightly (equal torque on both screws) to the mounting surface as shown in Figure 1.

Note: The heatsink should be mounted so the fins are vertical. This allows natural convection to help remove heat from the heatsink/SSR. If the heatsink is mounted with the fins horizontal the relay can carry only 80% of its rated maximum current.

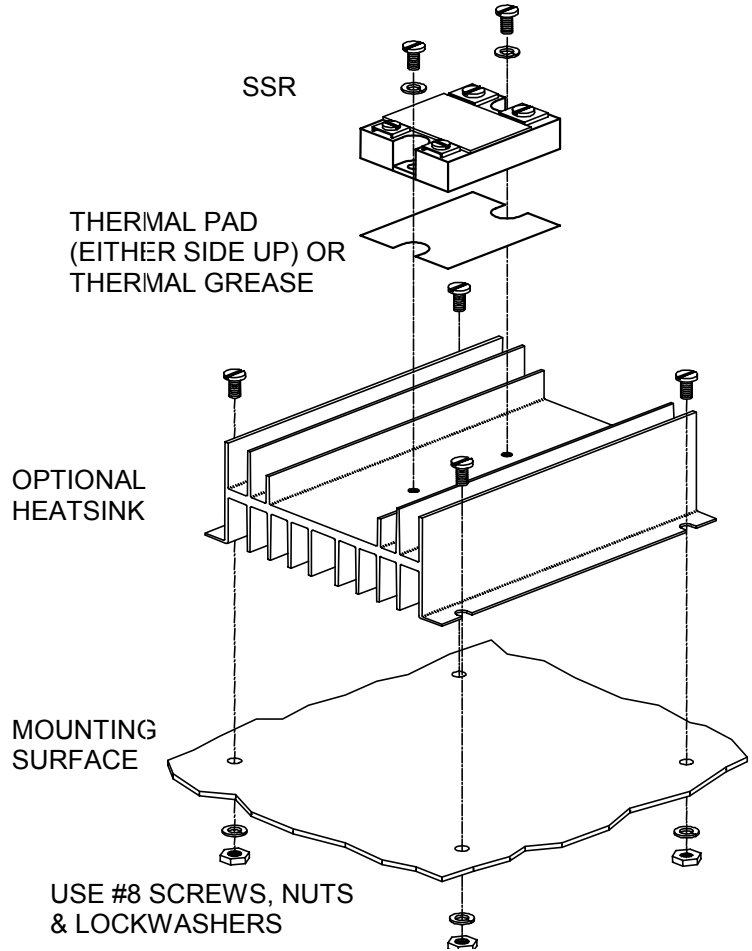

Figure 1 Assembly of an SSR to an optional heatsink

Transient Protection

All loads are inductive, even ones that are not so-labeled. An inductive load will produce harmful transient voltages when it is turned off. The more perfect the switch, the larger the transient voltages; the MOSFET output of this SSR is so nearly an ideal switch that the transient voltages produced by seemingly "non-inductive" loads can cause damage if not suppressed as in Figure 2. The diode used should be of the fast-recovery type with a reverse voltage rating at least equal to the supply voltage. Examples of fast-recovery diodes that may be used are G1856 (General Semiconductor) and 1N5406 (Vishay/LiteOn).

Input and output polarity must be observed. Inductive loads must be suppressed.

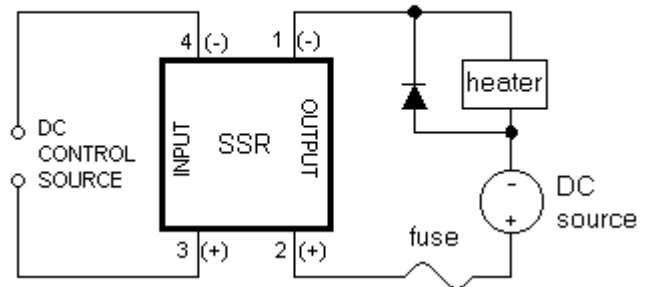
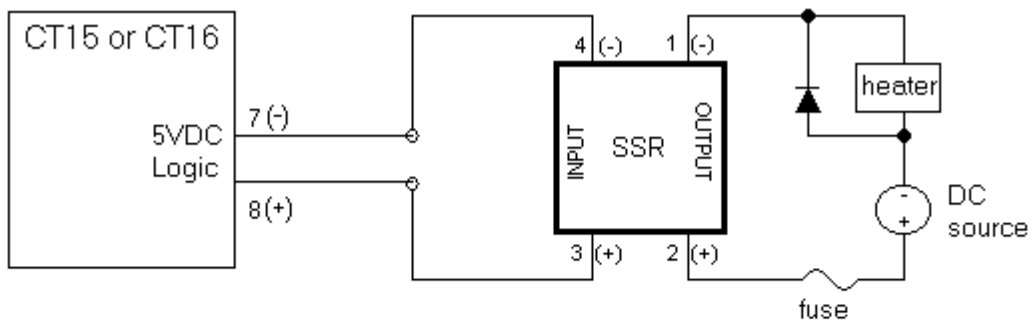
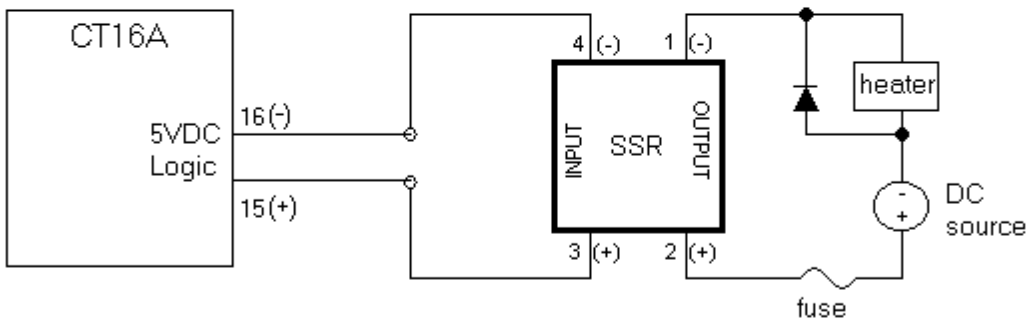

Figure 2 Wiring Diagram

Wiring Diagrams for CT15, CT16, and CT16A



CT16 has the option for a second logic output. The optional output will be wired in a similar manner, but uses pins 9(-) and 10(+).



CT16A has two outputs. Output A is shown in the diagram. Output B is wired in a similar manner, but uses pins 18(-) and 17(+).

Electrical Specifications

(25°C unless otherwise specified).

Data and Specifications subject to change without notice.

Output Characteristics		AC1009	UNITS
		D1D20	
Operating Voltage Range		0-100	Vdc
Max. Load Current ⁽¹⁾		20	Adc
Min. Load Current		20	mAdc
Max. Surge Current, 10ms. ⁽²⁾		42	Adc
F.W. Rect. Current		28	Apeak
Max. On-State Voltage @ Rated Current ⁽³⁾		2.1	Vdc
Thermal Resistance, (R _{θJC}) ⁽⁴⁾		1.06	°C/W
Power Dissipation @ Rated Current ⁽³⁾		41	Watts
Max. On-State Resistance @ Rated Current ⁽³⁾		0.10	Ohms
Max. Off-State Leakage Current @ Rated Voltage	T _j =125°C	12.0	mA
	T _j =25°C	0.3	
Input Characteristics			
Control Voltage Range		3.5-32	Vdc
Max. Reverse Voltage		-1.0	Vdc
Max. Turn-On Voltage ⁽⁵⁾		3.5	Vdc
Min. Turn-Off Voltage ⁽⁵⁾		1.0	Vdc
Min. Input Impedance		1,000	Ohms
Max. Input Current	5 Vdc	1.6	mA
	32 Vdc	28	
Max. Turn-On Time (T _d +T _r)		100	μsec
Max. Turn-Off Time (T _d +T _f)		1.0	msec
General Characteristics		Approval UL E116950	
Min. Dielectric Strength (60Hz) ⁽⁶⁾		2,500	Vrms
Min. Insulation Resist. (500 Vdc) ⁽⁶⁾		10 ⁹	Ohms
Max. Capacitance Input/Output		50	pF
Ambient Temperature Range	Operating	-30 to 80	°C
	Storage	-40 to 125	

Notes:

1. See Figure 4.
2. See Figure 5.
3. Case temperature T_C=80°C
4. Junction Temperature T_j (max.)=125°C
5. Over temperature range -30°C≤T_A≤80°C
6. Dielectric strength and the insulation resistance are measured between input and output.

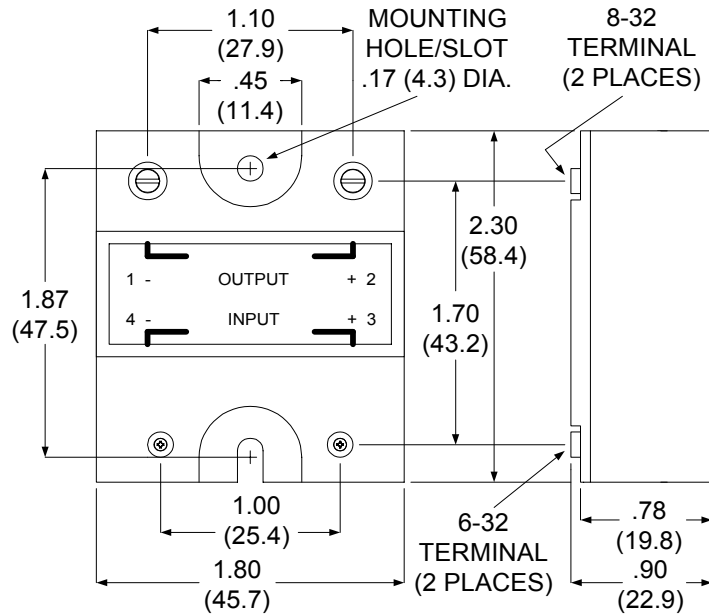

All dimensions are in inches (millimeters)

Screw torque requirements: 6-32 screws, 10 in-lb; 8-32 and 10-32 screws, 20 in-lb (screws dry without grease).

Figure 3 Dimensional Drawing

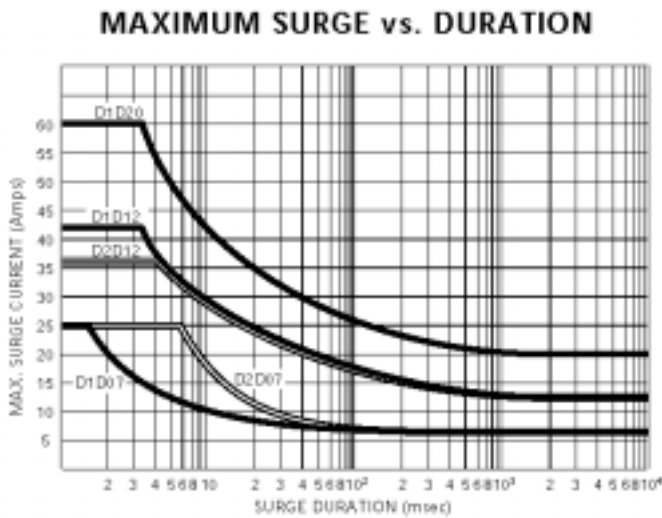

Figure 4 Thermal Derating Curve

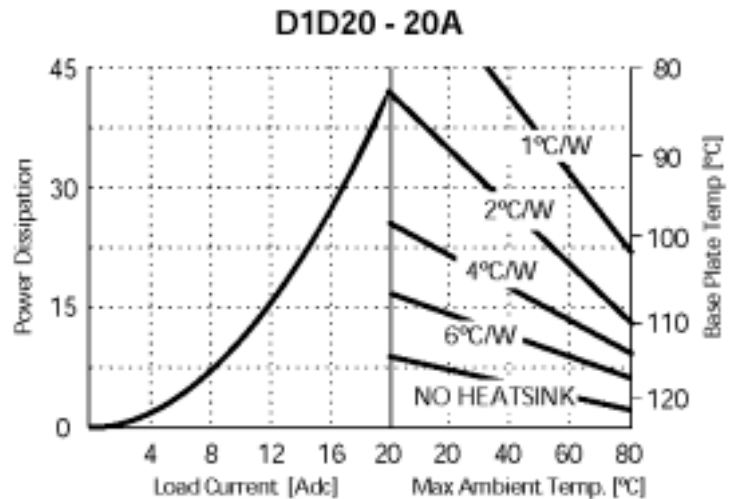

Figure 5 Surge Characteristics

Applies to a nonrepetitive, uniform amplitude surge of a given time and peak current, preceded by an off-state and followed by any rated load condition. The junction temperature must be allowed to fall below 80°C before reapplication of surge.

MINCO PRODUCTS, INC.

7300 Commerce Lane / Minneapolis, Minnesota 55432
Telephone: (763) 571-3121 Fax: (763) 571-0927

G:\MOD\AC1009\PRD\826MN.doc
STOCK NO. 360-00072 02/28/01 DAC